

Model Name	AXN10M480B	Total power output for different bi-facial gain coefficients			
		5%	10%	20%	30%
Maximum Power (+3%)	480W	504W	528W	576W	624W
Voc (V)	42.81	42.81	42.81	42.81	42.81
Isc (A)	13.74	14.43	15.11	16.49	17.86
Vmp (V)	36.93	36.93	36.93	36.93	36.93
Imp (A)	12.99	13.64	14.29	15.59	16.89
Module Efficiency (%)	21.9%	25.8%	27.0%	29.5%	31.9%
Series Fuse Rating	30A	<p>Bi-Facial modules produce power on both front and back. The actual power output from the back side is determined by installation conditions.</p> <p>Nominal bi-facial module gain coefficient can run from 5% to 30% or more, depending on the installation height and the amount of indirect irradiance.</p> <p>It is recommended to design the electrical circuits with safety factor that accounts for the additional power in order to protect electrical hardware.</p>			
Junction Box Protection	IP68				
Maximum System Voltage	VDC1500				
Operating Temperature	-40°C to 85°C				
Module type	Framed Bi-Facial Double Glass				
Connector type	Staubli EVO-2A				
Cable length	12AWG 1200mm ⁱⁱ				
Maximum snow/wind load	5400Pa(snow)/5400Pa(wind)				
Certification/Fire Type	UL61730 ⁱⁱ ; UL1703 Fire Type 3				

i) Amphenol connectors available upon request, ii) Cable length may be customized, iii) Additional certifications available upon request

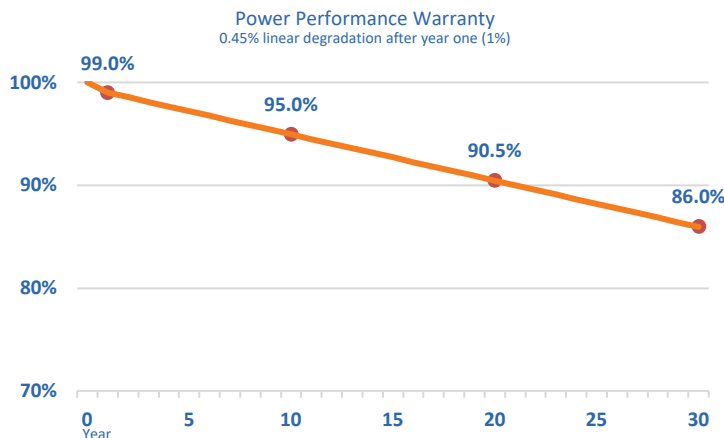
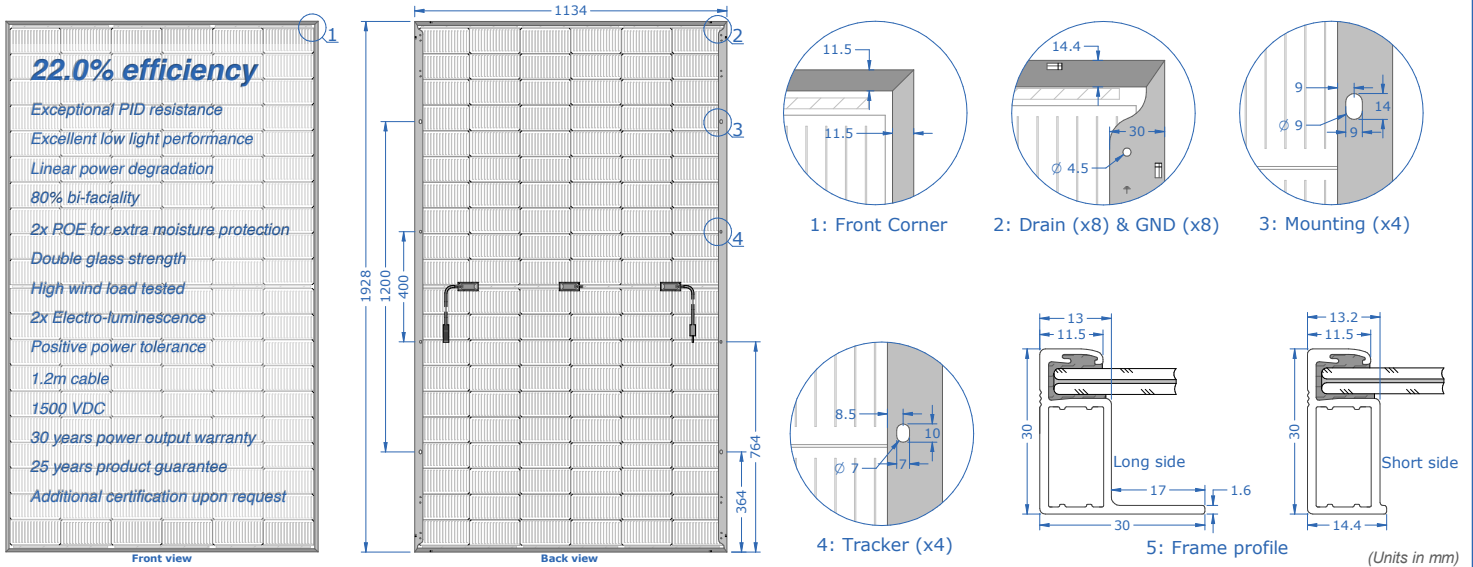

Mechanical Characteristics	
Frame	Anodized Aluminum (Silver and Black)
Solar Panel	57.27 lbs/25.98 kg 75.91" x 44.65" x 1.18" 1928mm x 1134mm x 30mm
Shipping Pallet	37 pcs per pallet 2197 lbs/997 kgs 79.92" x 48.66" x 48.70" 2030mm x 1236mm x 1237mm
Container	19 pallets (703 pcs) per 53'
Temperature Coefficients	
NOCT	45 °C
Isc/Voc (per °C)	+0.05%/-0.25%
Pmax (per °C)	-0.29%
Standard Test Conditions (STC)	
Irradiance	1000W/m ²
Module Temperature	25 °C
AM	1.50

Specifications subject to change without notice